

# 2026 Nationals

## Bareback Equitation (Youth Amateur)

Show Date: 04-23-2026

www.HorseShowPatterns.com

www.HorseShowPatterns.com

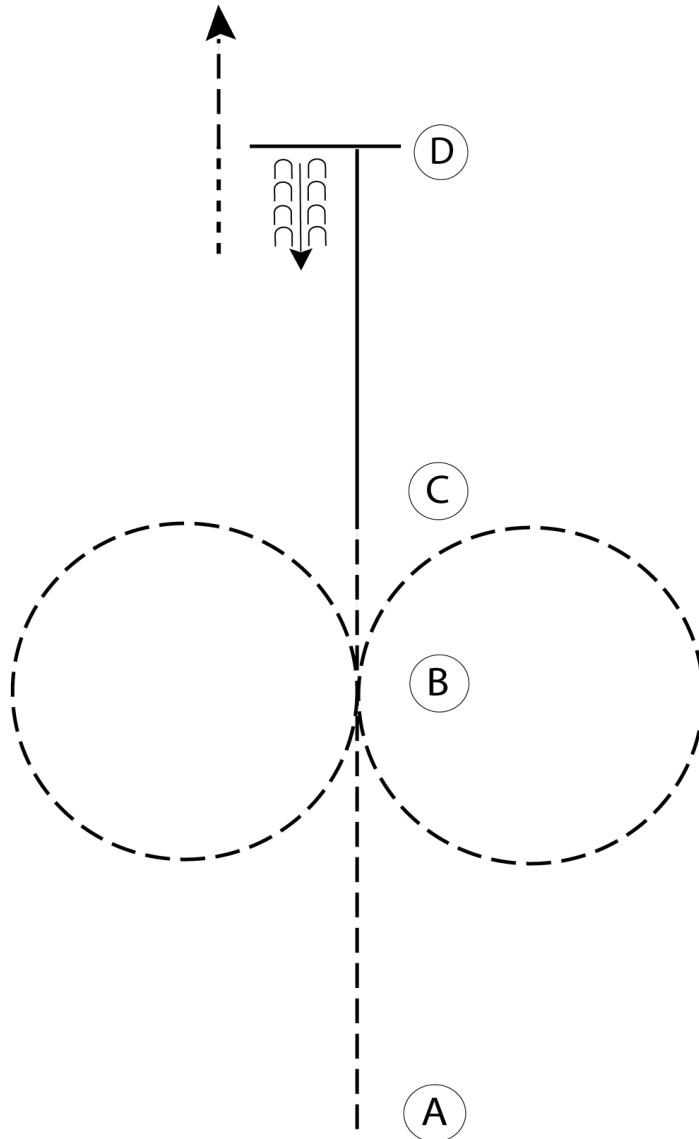

1. Sitting trot from A to B
2. Perform a figure eight at the posting trot starting to the right
3. Continue posting trot to C
4. Canter right lead to D
5. At D stop and back five steps
6. Walk five steps and trot to the line

Walk	-----
Trot	- - - - -
Extended Trot	-----
Canter	-----
Leg Yield	
Lead Change	— / —
Back	← C C C C
Marker	(B)
Sidepass	← - - - - →
Hand Gallop	-----

[HSE/1-5]

**Pattern Provided by:**  
*Shannon Walker*

# 2026 Nationals

## Western Riding (Amateur, Youth, Open)

Show Date: 04-23-2026

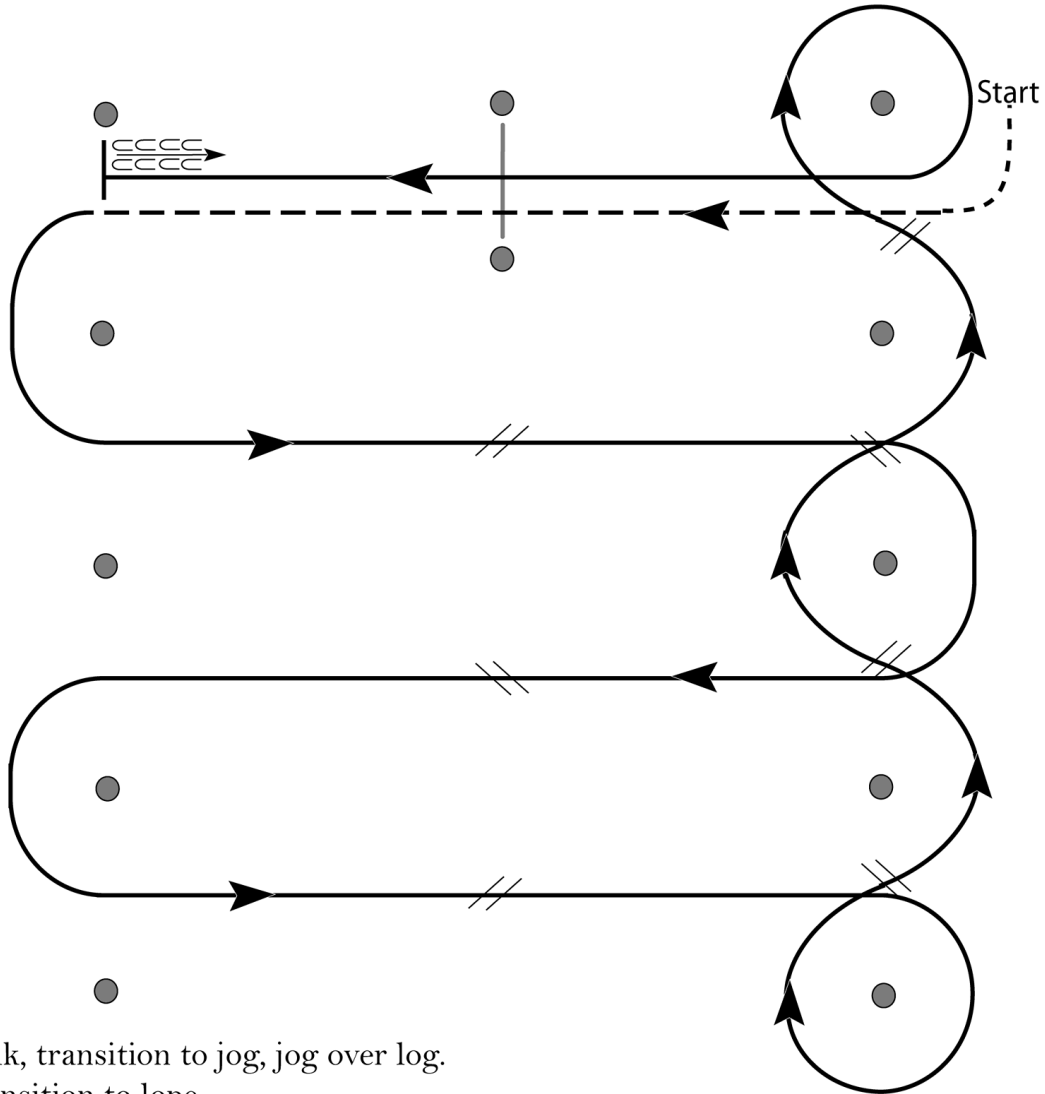

1. Walk, transition to jog, jog over log.
2. Transition to lope.
3. First crossing change.
4. Second crossing change.
5. Third crossing change.
6. Circle and first line change.
7. Second line change.
8. Third line change.
9. Fourth line change and circle.
10. Lope log.
11. Lope, stop and back.

[WR/OP-2]

Pattern Provided by:  
*Shannon Walker*

# 2026 Nationals

## Western Riding (All L1)

Show Date: 04-23-2026

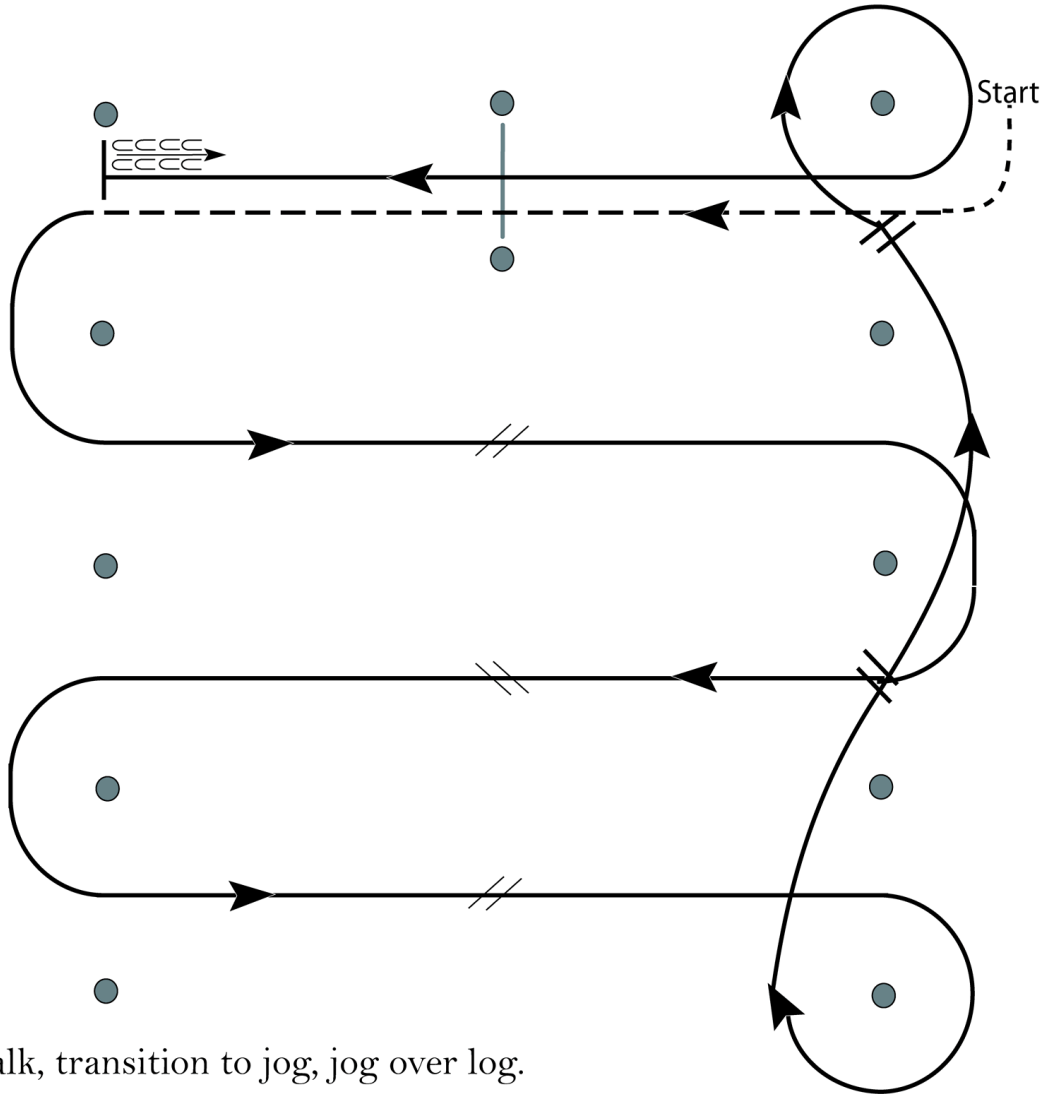

1. Walk, transition to jog, jog over log.
2. Transition to left lead lope.
3. First crossing change.
4. Second crossing change.
5. Third crossing change.
6. Circle and first line change.
7. Second line change and circle.
8. Lope log.
9. Stop and back.

[WR/GP-2]

Pattern Provided by:  
*Shannon Walker*



# 2026 Nationals

Western Horsemanship (JR SR Youth, Jnr Horse, Novice Amateur)

Show Date: 04-23-2026

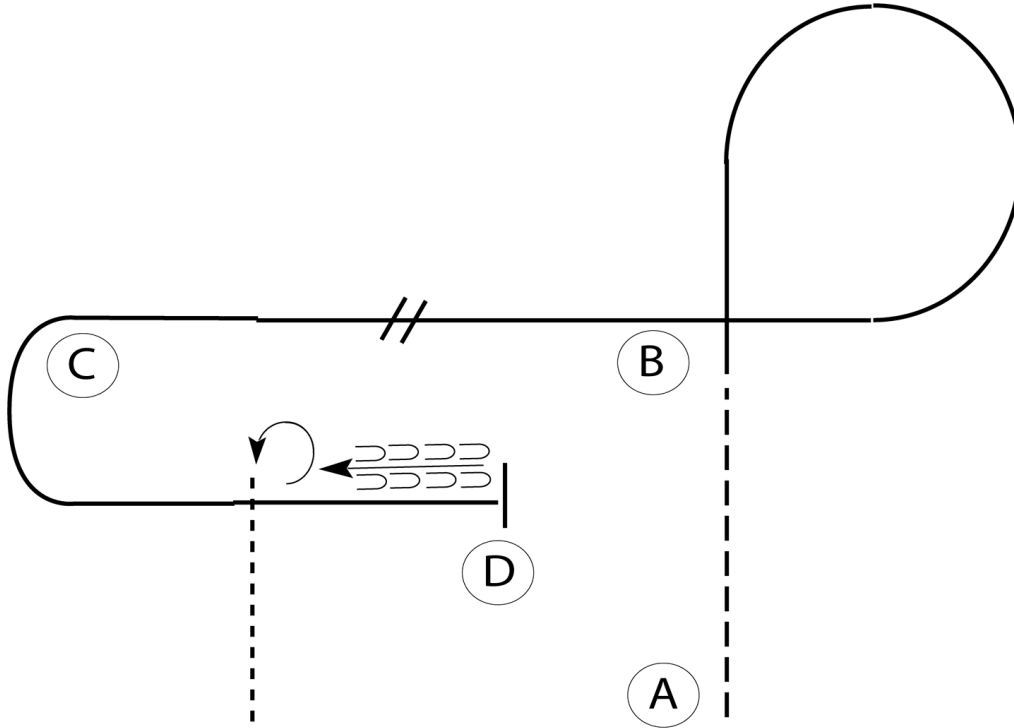

Be ready at A.

1. Jog from A to B.
2. Lope a circle to the right.
3. Halfway between B and C, perform a simple lead change.
4. Lope on the left lead to D.
5. Stop at D and back approximately one horse length.
6. Spin 3/4 turn to the left and walk off.

Follow the instructions of your ring steward.

Walk	.....
Jog	-----
Extended Jog	- - - - -
Lope	—————
Leg Yield	
Lead Change	— / —
Back	← — — — —
Marker	(B)
Sidepass	← — — — — →

[WH/2-70]

Pattern Provided by:  
*Shannon Walker*

w w w . H o r s e S h o w P a t t e r n s . c o m

w w w . H o r s e S h o w P a t t e r n s . c o m

# 2026 Nationals

## Hunt Seat Equitation (Amateur, Masters)

Show Date: 04-23-2026

w w w . H o r s e S h o w P a t t e r n s . c o m

w w w . H o r s e S h o w P a t t e r n s . c o m

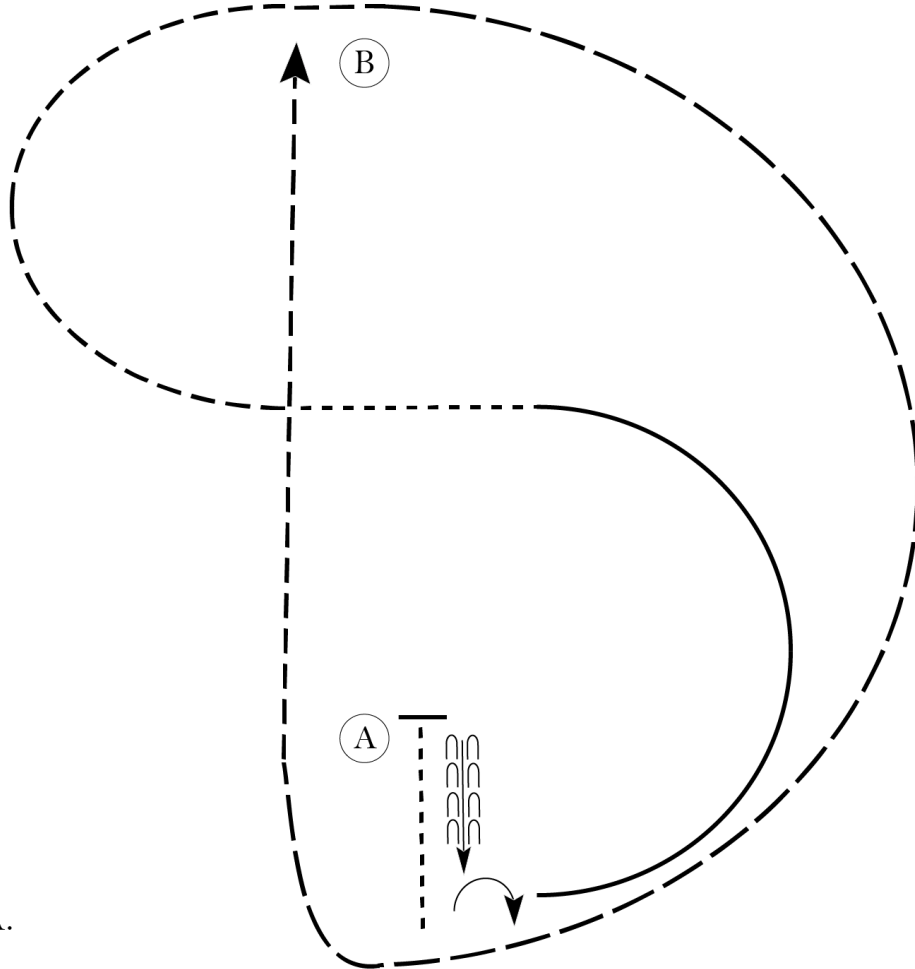

Be ready before A.

1. Walk to A, stop and back approximately one horse length.
2. Perform a 90 degree forehand turn right.
3. Canter on the left lead in a half circle to center of pattern.
4. Walk 2-3 horse lengths.
5. Sitting trot in a half circle to B.
6. Hand gallop on the right lead to and around A.
7. Trot on the left diagonal to B.

Pattern is over once you pass B.

Walk	-----
Trot	- - - - -
Extended Trot	-----
Canter	—————
Leg Yield	
Lead Change	↙ ↘
Back	←←←←←
Marker	⊙
Sidepass	←---→
Hand Gallop	-----

[HSE/3-67]

Pattern Provided by:  
*Shannon Walker*

# 2026 Nationals

## Hunt Seat Equitation (Jnr Snr youth, Novice Amateur)

Show Date: 04-23-2026

www.HorseShowPatterns.com

www.HorseShowPatterns.com

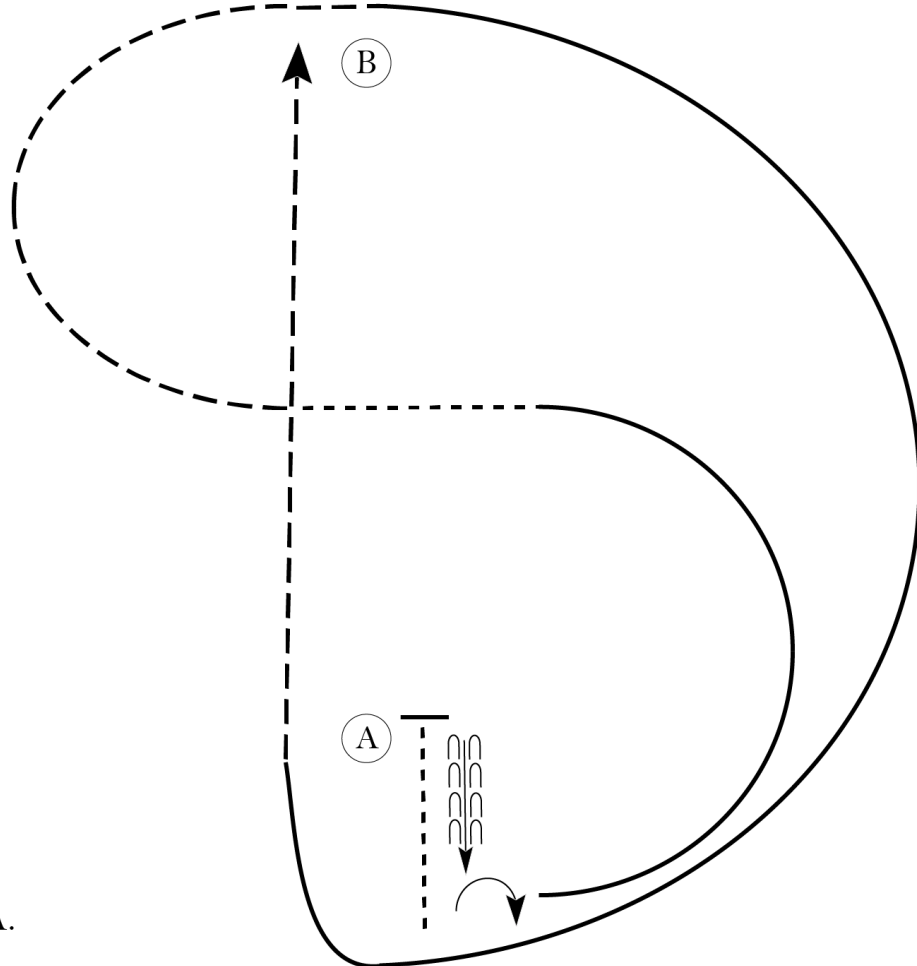

Be ready before A.

1. Walk to A, stop and back approximately one horse length.
2. Perform a 90 degree forehand turn right.
3. Canter on the left lead in a half circle to center of pattern.
4. Walk 2-3 horse lengths.
5. Sitting trot in a half circle to B.
6. Canter on the right lead to and around A.
7. Trot on the left diagonal to B.

Pattern is over once you pass B.

Walk	-----
Trot	- - - - -
Extended Trot	-----
Canter	—————
Leg Yield	
Lead Change	↘ ↙
Back	← ← ← ← ←
Marker	⊙
Sidepass	← - - - - →
Hand Gallop	—————

[HSE/2-67]

**Pattern Provided by:**  
*Shannon Walker*

# 2026 Nationals

## Reining (All)

Show Date: 04-23-2026

### REINING PATTERN I

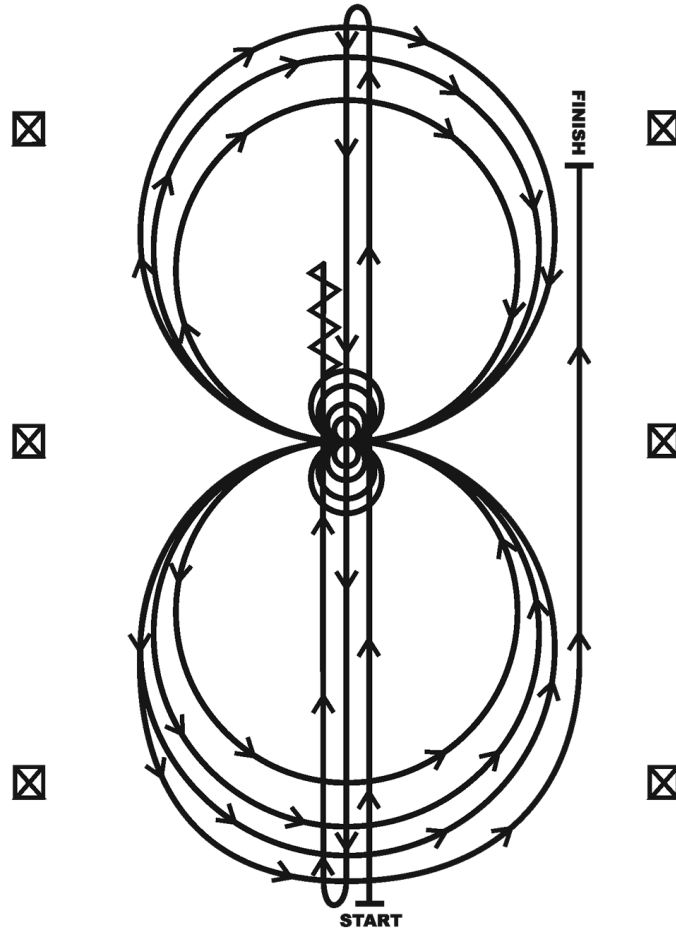

1. Run at speed to the far end of the arena past the endmarker and do a left rollback—no hesitation.
2. Run to the opposite end of the arena past the end marker and do a right rollback—no hesitation.
3. Run past the center marker and do a sliding stop. Back up to center of the arena or at least ten feet (three meters). Hesitate.
4. Complete four spins to the right. Hesitate.
5. Complete four and one-quarter spins to the left so that horse is facing left wall or fence. Hesitate.
6. Beginning on the left lead, complete three circles to the left: the first circle large and fast; the second circle small and slow; the third circle large and fast. Change leads at the center of the arena.
7. Complete three circles to the right: the first circle large and fast; the second circle small and slow; the third circle large and fast. Change leads at the center of the arena.
8. Begin a large circle to the left but do not close this circle. Run straight up the right side of the arena past the center marker and do a sliding stop at least twenty feet (six meters) from wall or fence. Hesitate to demonstrate the completion of the pattern.

[R/AQHAP-1]

Pattern Provided by:  
*Shannon Walker*

# 2026 Nationals

## Ranch Riding (All)

Show Date: 04-23-2026

w w w . H o r s e S h o w P a t t e r n s . c o m

w w w . H o r s e S h o w P a t t e r n s . c o m

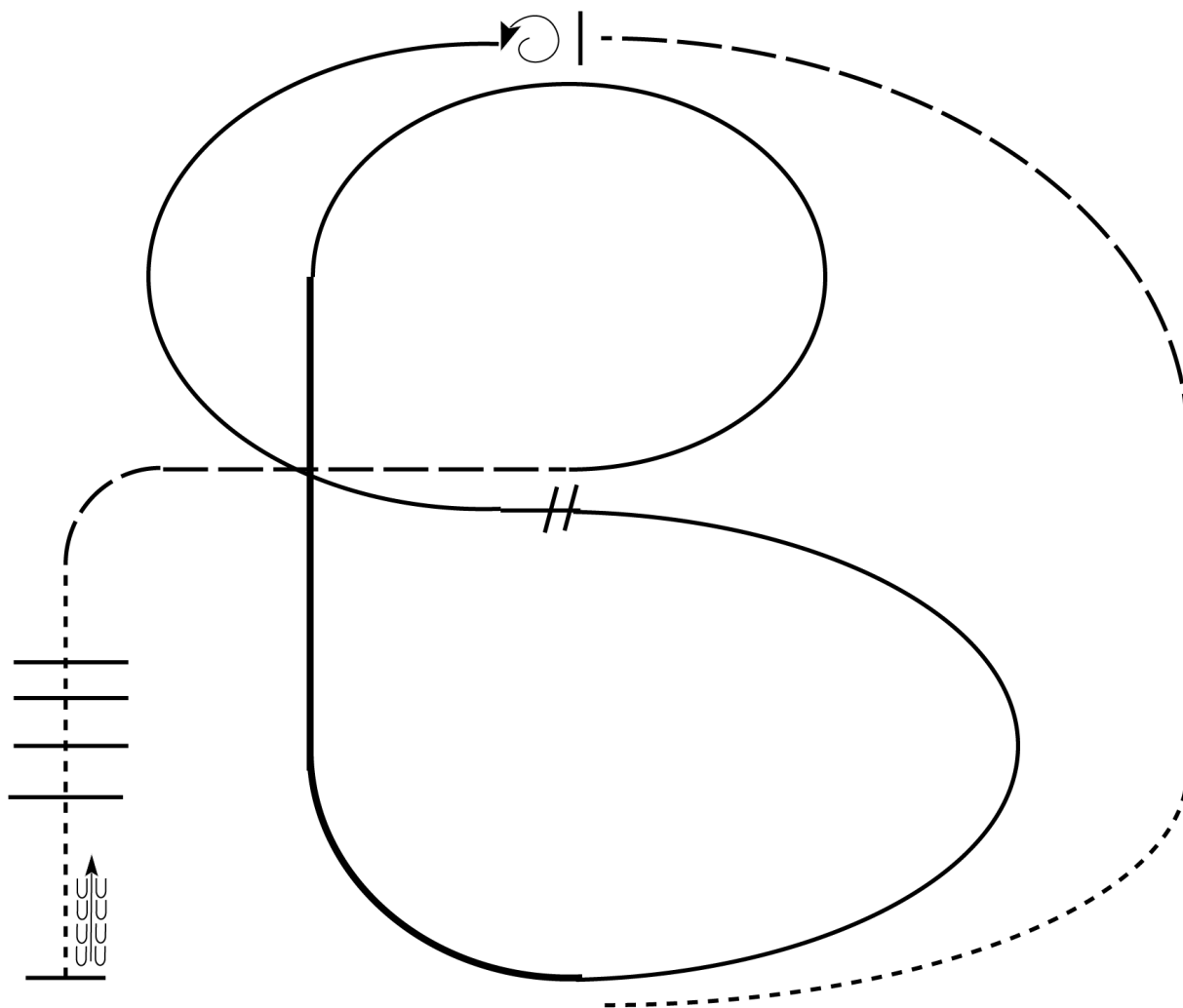

1. Walk
2. Trot
3. Extend the trot, at the top of the arena, stop
4. 360 degree turn to the left
5. Left lead 1/2 circle, lope to the center
6. Change leads (simple or flying)
7. Right lead 1/2 circle
8. Extended lope up the long side of arena (right lead)
9. Collect back to a lope around the top of the arena and back to center
10. Break down to an extended trot
11. Walk over poles.
12. Stop and back

<b>Walk</b>	-----
<b>Jog</b>	- - - - -
<b>Extended Jog</b>	-----
<b>Lope</b>	
<b>Lead Change</b>	//
<b>Back</b>	←
<b>Marker</b>	(B)

[RR/1]

**Pattern Provided by:**  
*Shannon Walker*

# 2026 Nationals

## Showmanship (Small Fry)

Show Date: 04-23-2026

w w w . H o r s e S h o w P a t t e r n s . c o m

w w w . H o r s e S h o w P a t t e r n s . c o m

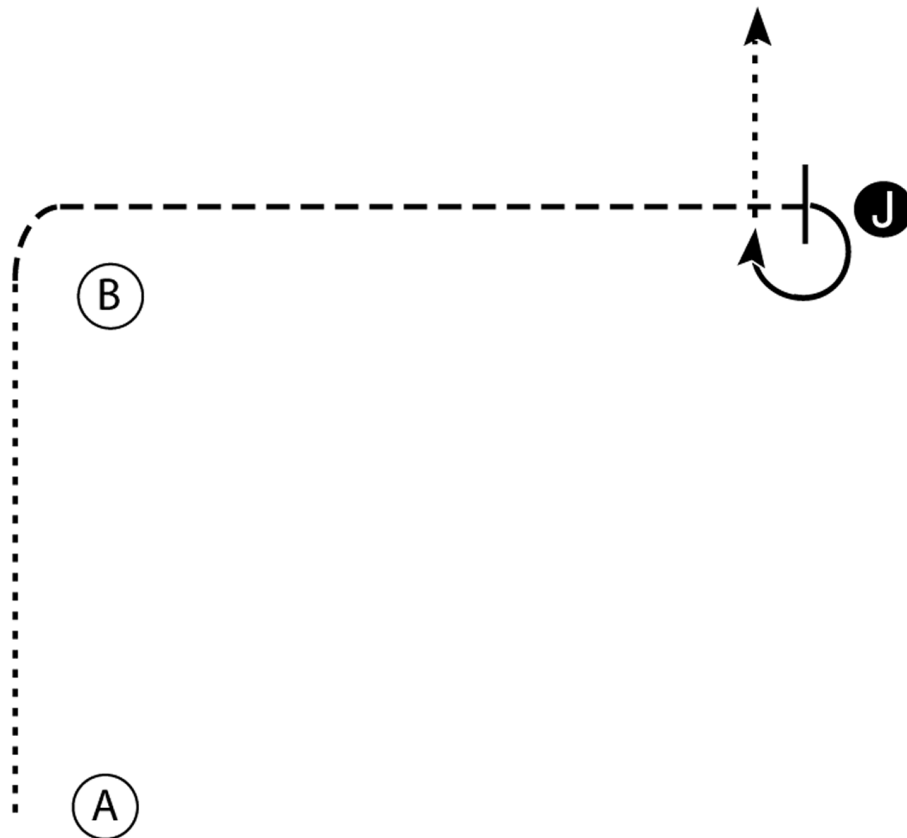



1. Walk from A to B.
2. Trot from B to the Judge.
3. Stop and set up for inspection.
4. When dismissed perform a 270 degree turn and walk straight away from the Judge.

Walk 

Trot 

Back 

Marker 

Judge 

[SWT-2]

Pattern Provided by:  
*Shannon Walker*

# 2026 Nationals

## Showmanship (Jnr Snr Youth, Novice Amateur)

Show Date: 04-23-2026

w w w . H o r s e S h o w P a t t e r n s . c o m

w w w . H o r s e S h o w P a t t e r n s . c o m

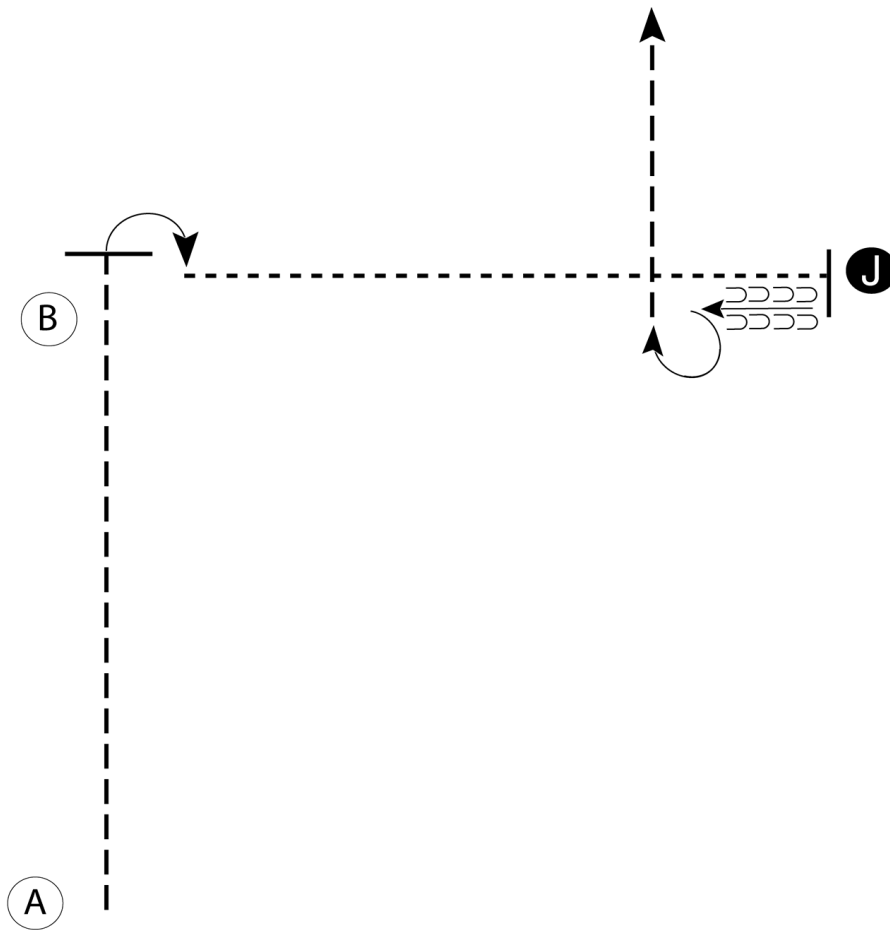

1. Begin at A. Trot from A past B
2. Stop and perform a 90 degree turn
3. Walk to the Judge, stop and set up for inspection
4. When dismissed back one horse length and perform a 270 degree turn
5. Trot to the line-up

- Walk - - - - -
- Trot - - - - -
- Back ←
- Marker (B)
- Judge (J)

[S/1-14]

Pattern Provided by:  
*Shannon Walker*

# 2026 Nationals

## Showmanship (Amateur, Masters)

Show Date: 04-23-2026

w w w . H o r s e S h o w P a t t e r n s . c o m

w w w . H o r s e S h o w P a t t e r n s . c o m

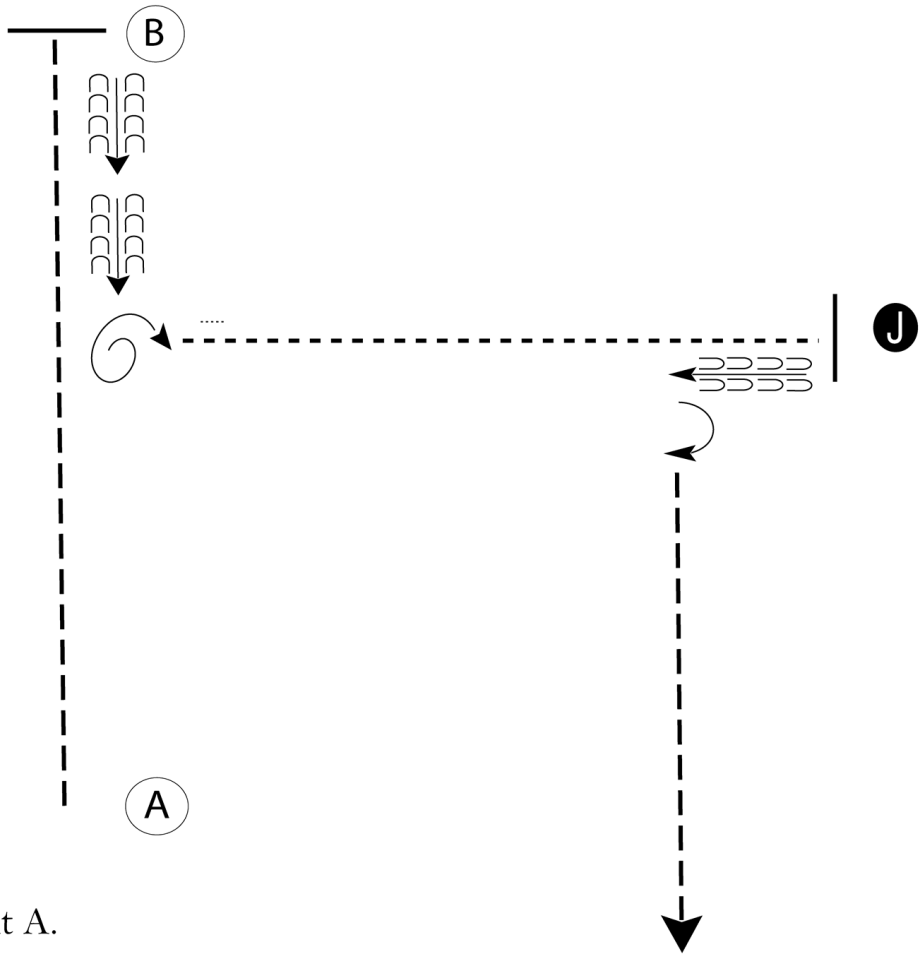

Be ready at A.

1. Trot to B and stop.
2. Back until even with judge.
3. Perform a 450 degree turn. Walk to judge.
4. Stop, set up, inspection.
5. When dismissed, back approximately one horse length.
6. Perform a 90 degree turn.
7. Trot to the line up or follow the directions of the ring steward.

Walk	-----
Trot	- - - - -
Back	← C C C C C C
Marker	ⓑ
Judge	ⓙ

[S/3-29]

Pattern Provided by:  
*Shannon Walker*

# RANCH REINING PATTERN 3

Youth, Open, Amateur, Masters

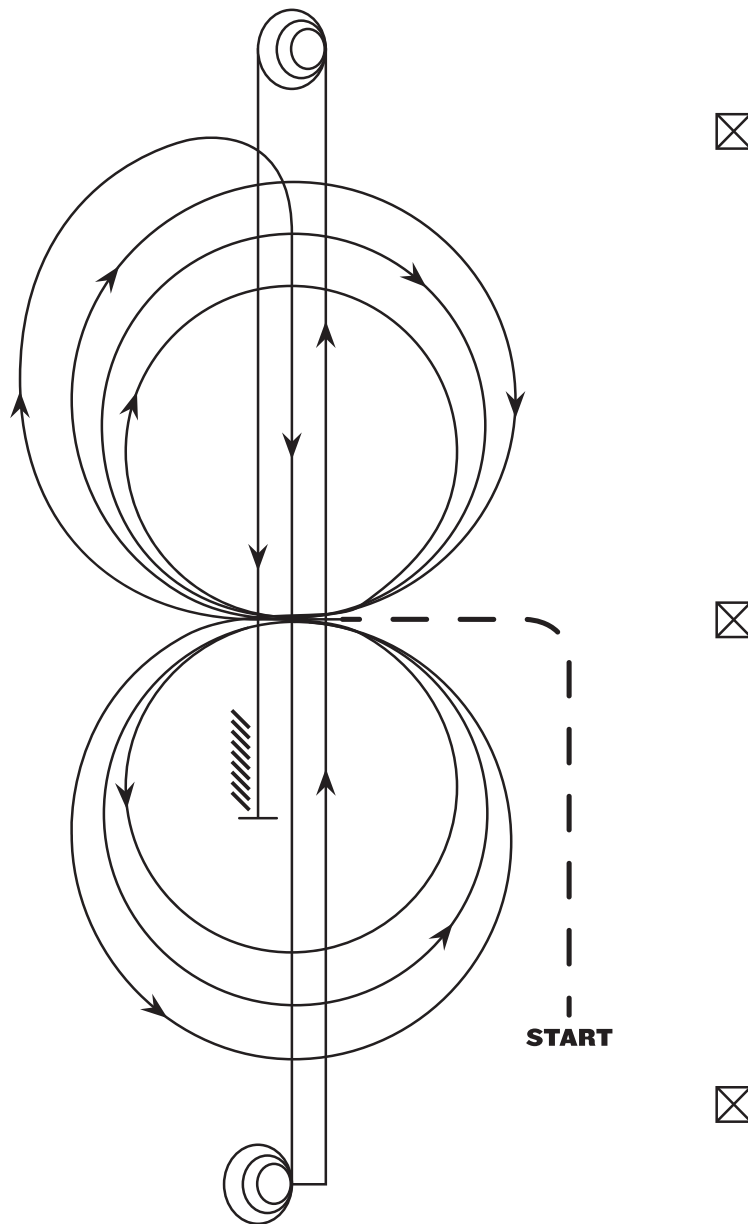

**Mandatory Marker along Fence or Wall:** The judge shall indicate with markers on arena fence or wall the center of pattern. Judge shall also place markers on fence or wall at least 50' from each end of the arena.

Ride pattern as follows: Trot to center of arena and stop or walk before departure. Start pattern facing toward judge.

1. Beginning on right lead, complete three circles to the right - the first two large and fast; the third one small and slow. Change leads at center of arena.
2. Complete three circles to the left - the first two large and fast; the third one small and slow. Change leads at center of arena.
3. Begin a large circle to the right, but do not close this circle. Run down center of arena, past the end marker, and do a sliding stop.
4. Complete 3 1/2 spins to the right.
5. Run up center of arena to the opposite end, past the end marker, do a sliding stop.
6. Complete 3 1/2 spins to the left.
7. Run back to the middle of the arena, past the center marker, and do a sliding stop. Back up at least 10 feet. Hesitate to show completion of pattern.

# RANCH REINING PATTERN 2

Snr Horse (v), Jnr Horse (v)

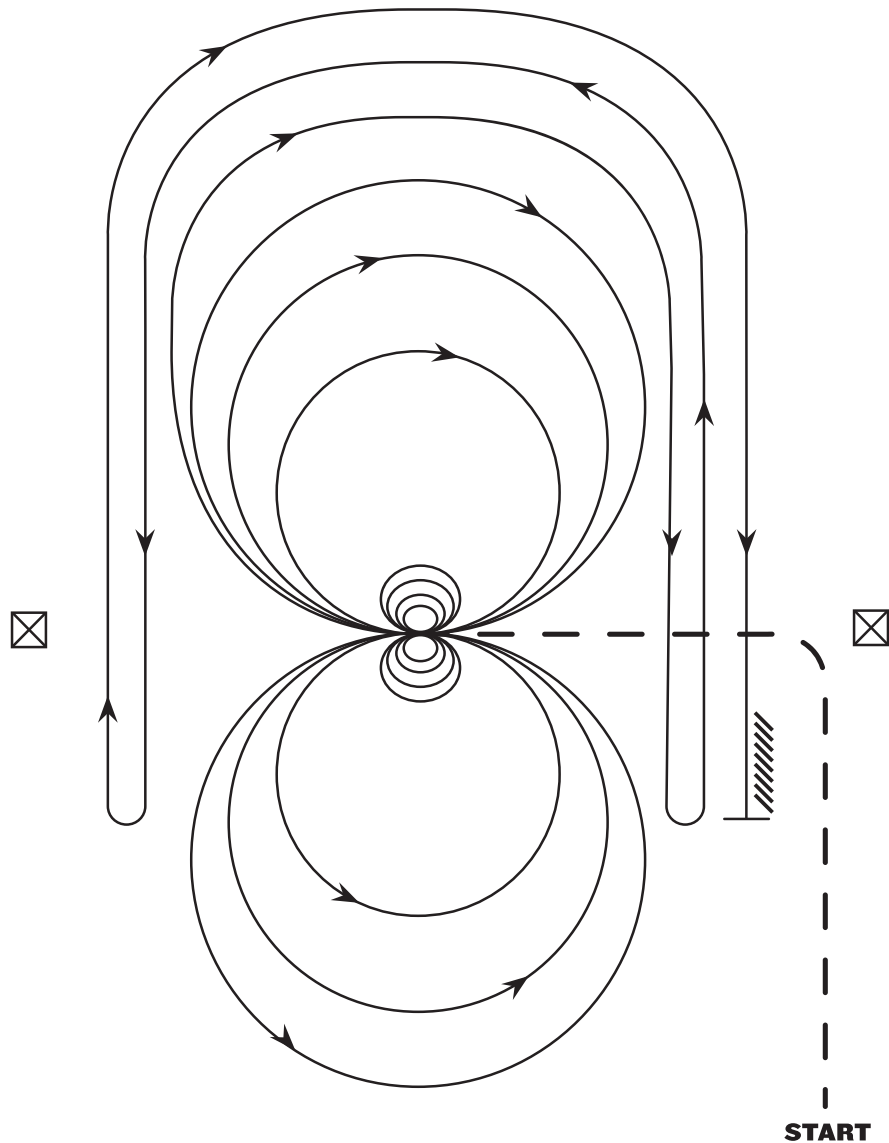

**Mandatory Markers along Fence or Wall:** The judge shall indicate with markers on arena fence or wall the center of pattern.

Ride pattern as follows: Trot to center of arena and stop or walk before departure.

1. Beginning on right lead, complete two circles to the right - the first one large and fast; the second one small and slow. Stop at center.
2. Complete 4 spins to the right. Hesitate.
3. Beginning on left lead, complete two circles to the left - the first one large and fast; the second one small and slow. Stop at center.
4. Complete 4 spins to the left. Hesitate.
5. Beginning on the right lead, complete a large fast circle to the right and change leads at center of arena. Complete a large fast circle to the left and change leads at center of arena.
6. Begin a large fast circle to the right, but do not close this circle. Run down the right side of the arena, past the center marker, and do a left roll back at least 20 feet from the wall or fence.
7. Continue back around the previous circle, but do not close this circle. Run down the left side of the arena, past the center marker, and do a right roll back at least 20 feet from the wall or fence.
8. Continue back around previous circle, but do not close this circle. Run down right side of the arena, past the center marker, and do a sliding stop at least 20 feet from the wall or fence. Back up at least 10 feet. Hesitate to show completion of pattern.

## WORKING COW HORSE PATTERN II

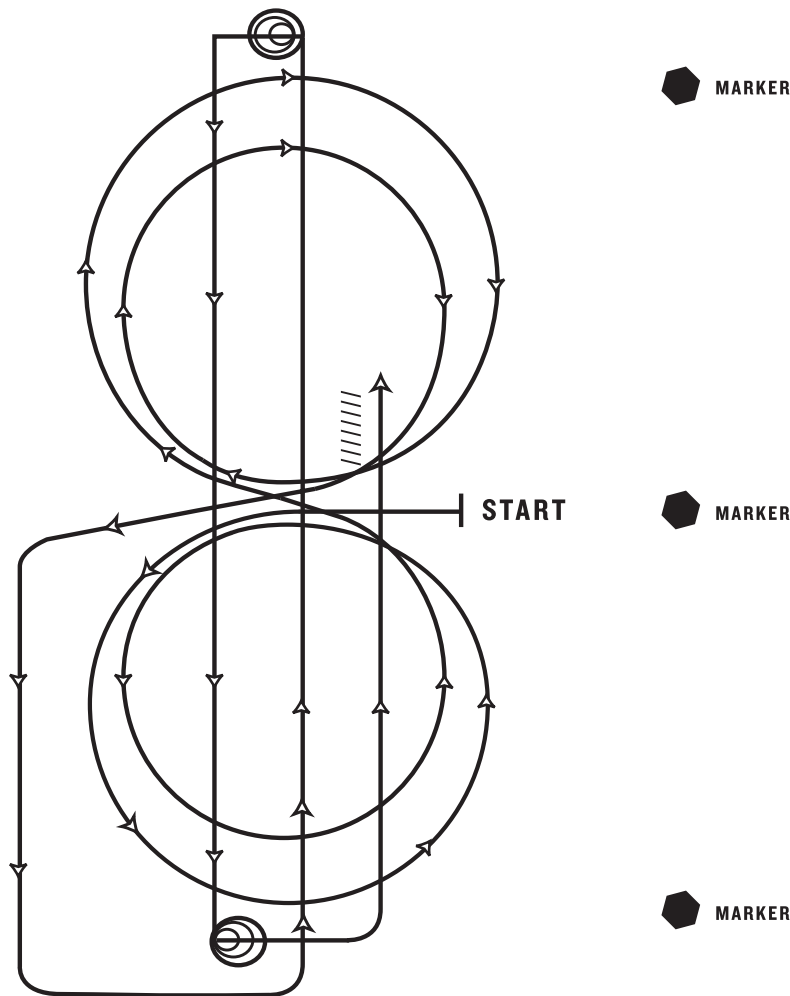

Trot to center of arena, stop. Start pattern facing towards judge

1. Beginning on the left lead, complete 2 circles to the left; the first circle large and fast, the second circle small and slow. Change leads at the center of the arena.
2. Complete 2 circles to the right; the first circle large and fast, the second circle small and slow. Change leads at the center of arena.
3. Continue around end of arena without breaking gait or changing leads, run down center of arena past end marker, and execute a square sliding stop.
4. Complete 3 1/2 spins to the left.
5. Run down center of arena past end maker, and execute a square sliding stop.
6. Complete 3 1/2 spins to the right.
7. Run down center of arena past center marker, and execute a square sliding stop. Back up at least 10 feet. Hesitate to complete pattern.

### Pattern II

- |                  |                      |
|------------------|----------------------|
| 1. Left circles  | 4. 3 1/2 left spins  |
| 2. Right circles | 5. Stop              |
| 3. Stop          | 6. 3 1/2 right spins |
|                  | 7. Stop and back up  |

This pattern may be used as a lope-in pattern; refer to SHW505.2.

# RANCH TRAIL

Youth, Masters, Jnr Horse (v), Snr Horse (v)

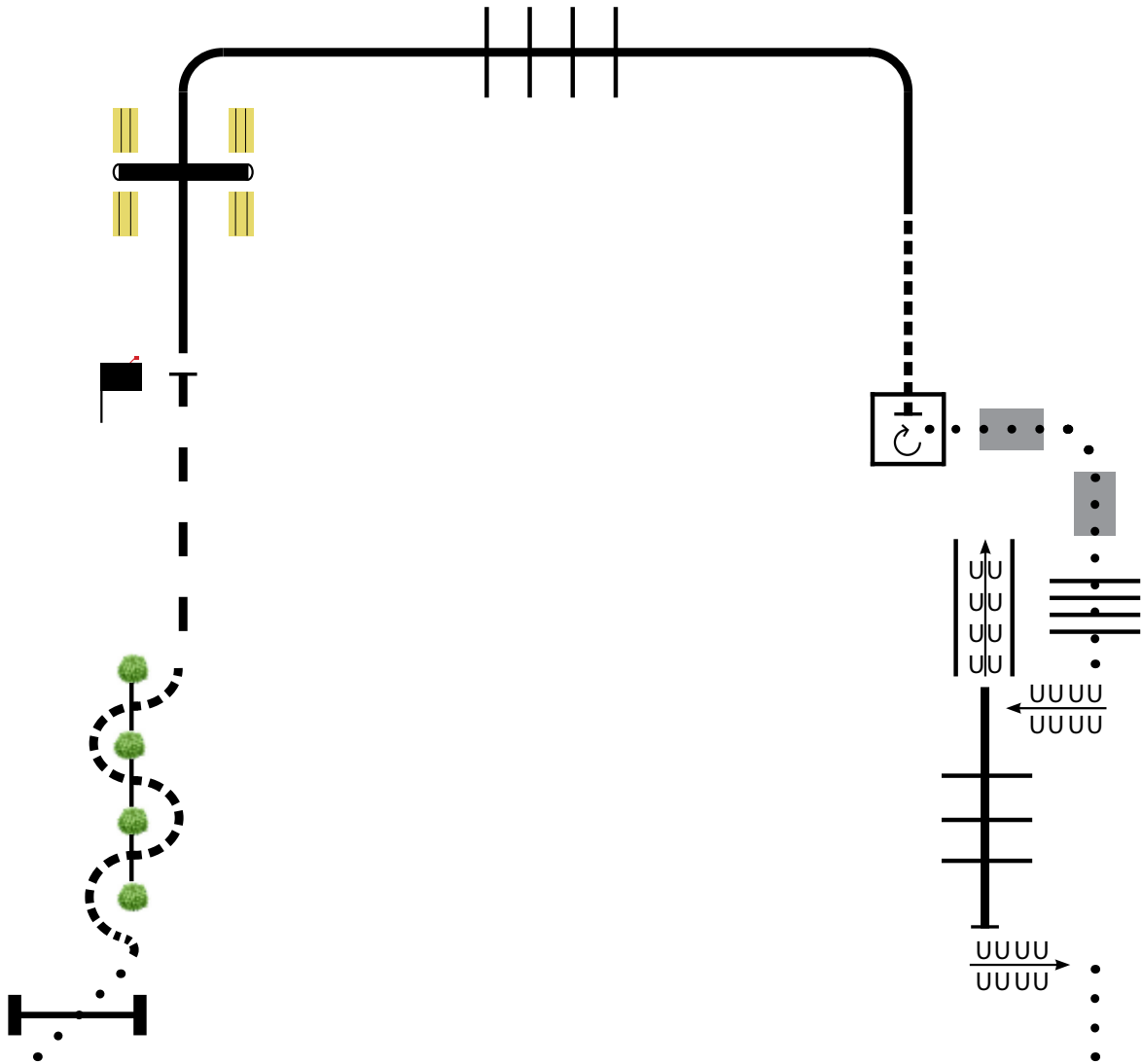

1. Left handed gate.
2. Trot serpentine.
3. Extended trot to mailbox.
4. Stop. Open and close mailbox.
5. Lope right lead chute over raised pole.
6. Lope right lead 4 logs.
7. Trot into box. 270° turn right.
8. Walk over bridges.
9. Walk poles.
10. Sidepass right.
11. Back chute.
12. Lope left lead 3 poles.
13. Sidepass left and walk out.

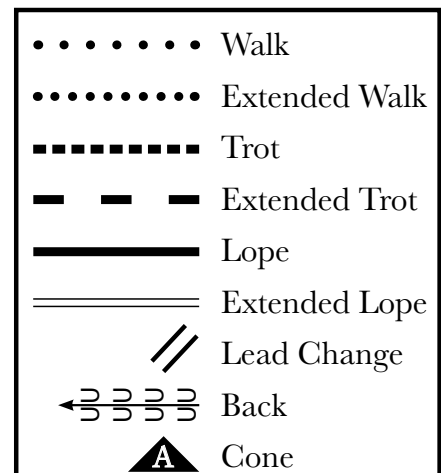

# RANCH TRAIL

## OPEN & AMATEUR

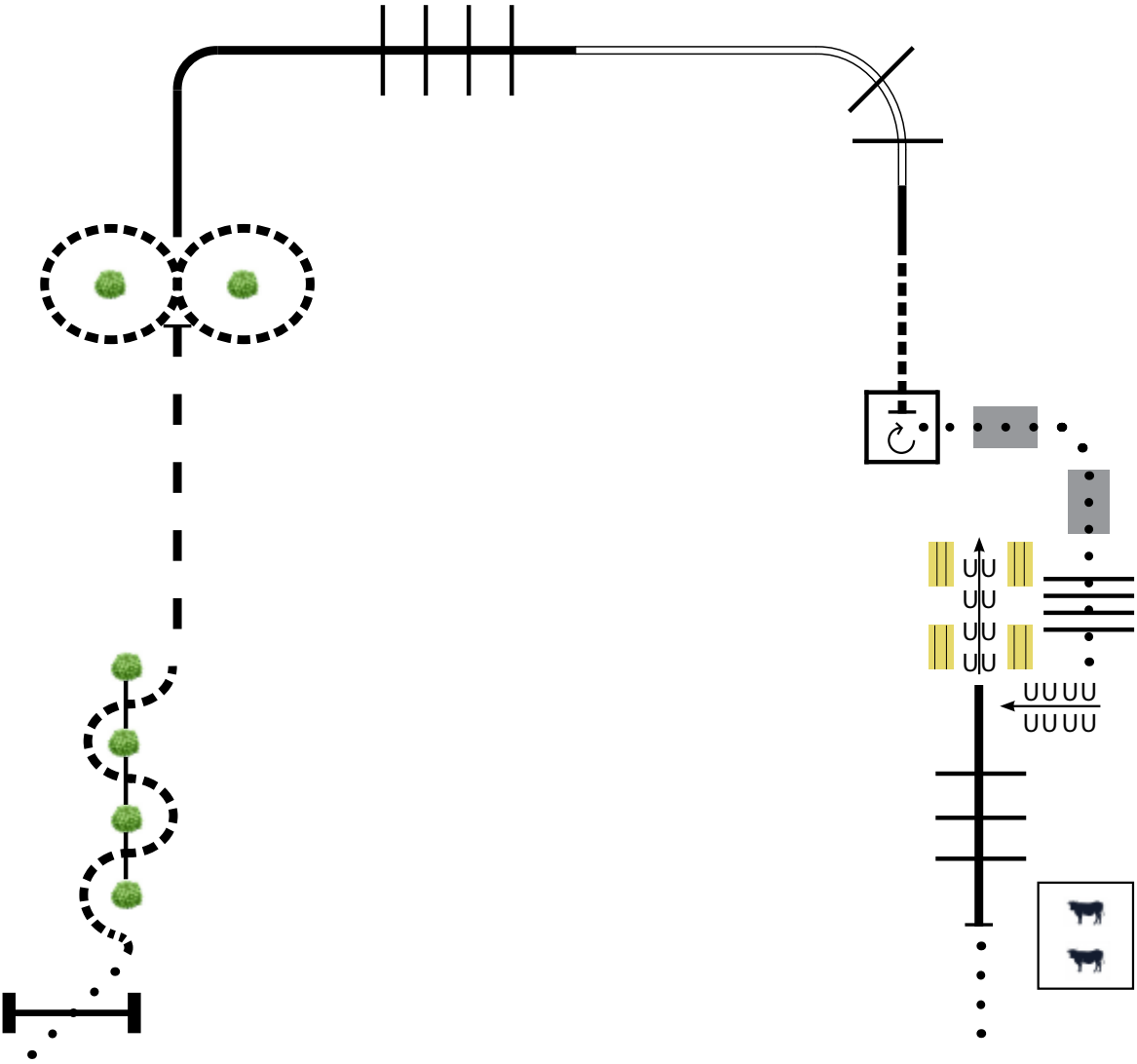

1. Left handed gate.
2. Trot serpentine. Extended trot to drag.
3. Stop. Drag figure eight going to the left first.
4. Lope right lead 4 poles.
5. Extended lope 2 poles. Collect lope.
6. Trot into box.
7. Stop. 270° turn right.
8. Walk over bridges.
9. Walk poles. Sidepass right.
10. Back chute of hay bales.
11. Lope left lead 3 poles.
12. Stop. Ground tie. Feed cattle.
13. Lead out.

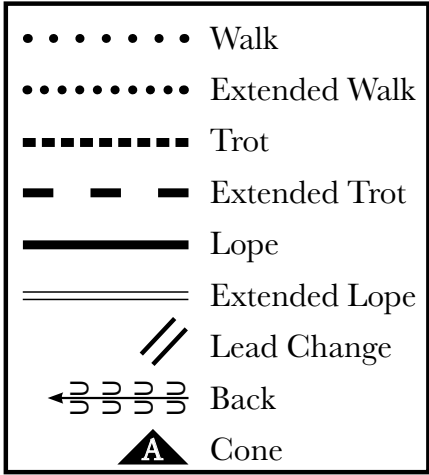

# 2026 Nationals

## Yearling Led Feature/ 2YO Led Feature Trail

### Classes I & J

www.HorseShowPatterns.com

www.HorseShowPatterns.com

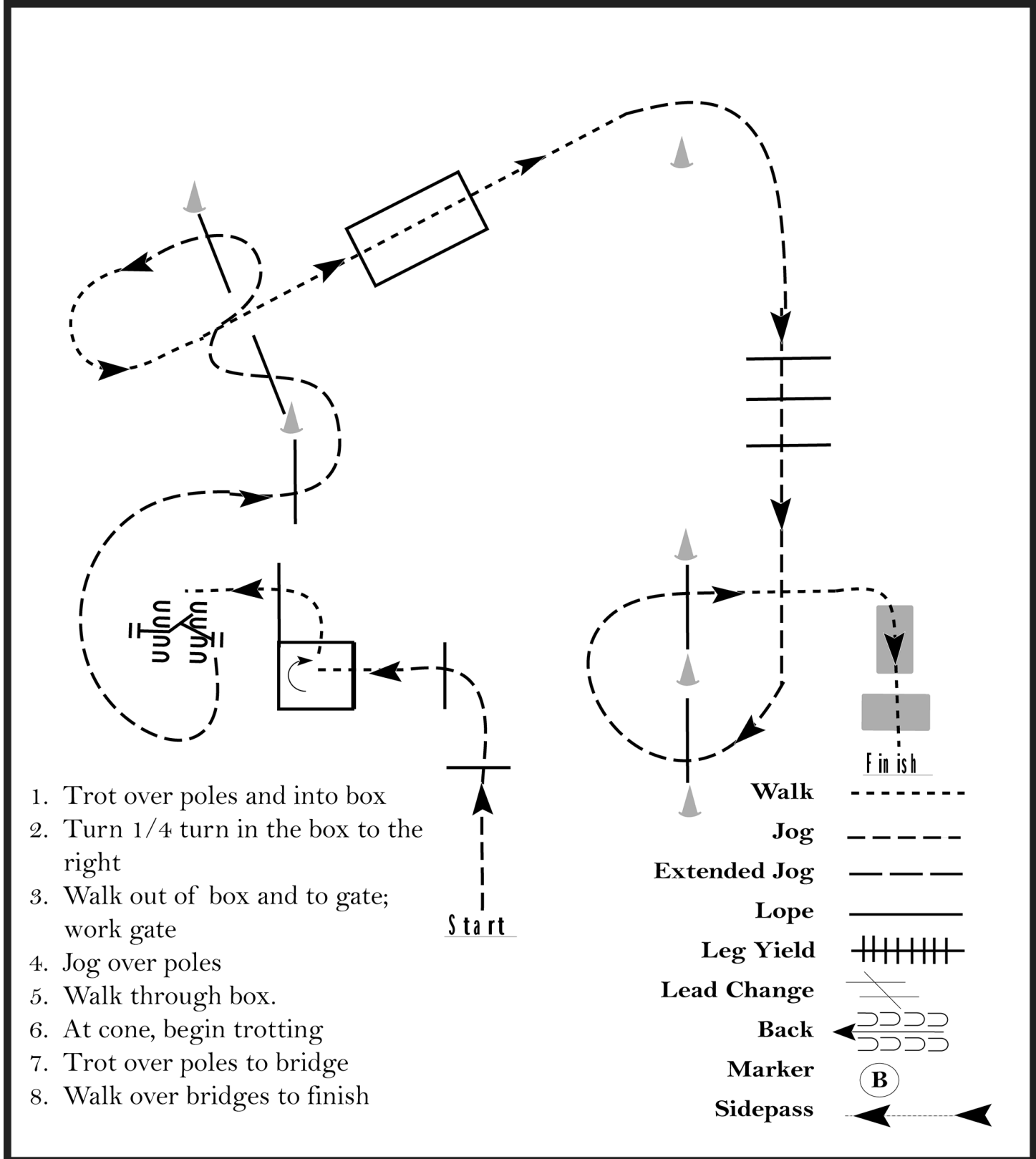

1. Trot over poles and into box
2. Turn 1/4 turn in the box to the right
3. Walk out of box and to gate; work gate
4. Jog over poles
5. Walk through box.
6. At cone, begin trotting
7. Trot over poles to bridge
8. Walk over bridges to finish

[T/1-1]

**Pattern Provided by:**  
*Shannon Walker*

**2026 Nationals**  
**3 YO Trail Feature/4YO Trail Feature**  
**Classes S & V**

www.HorseShowPatterns.com

www.HorseShowPatterns.com

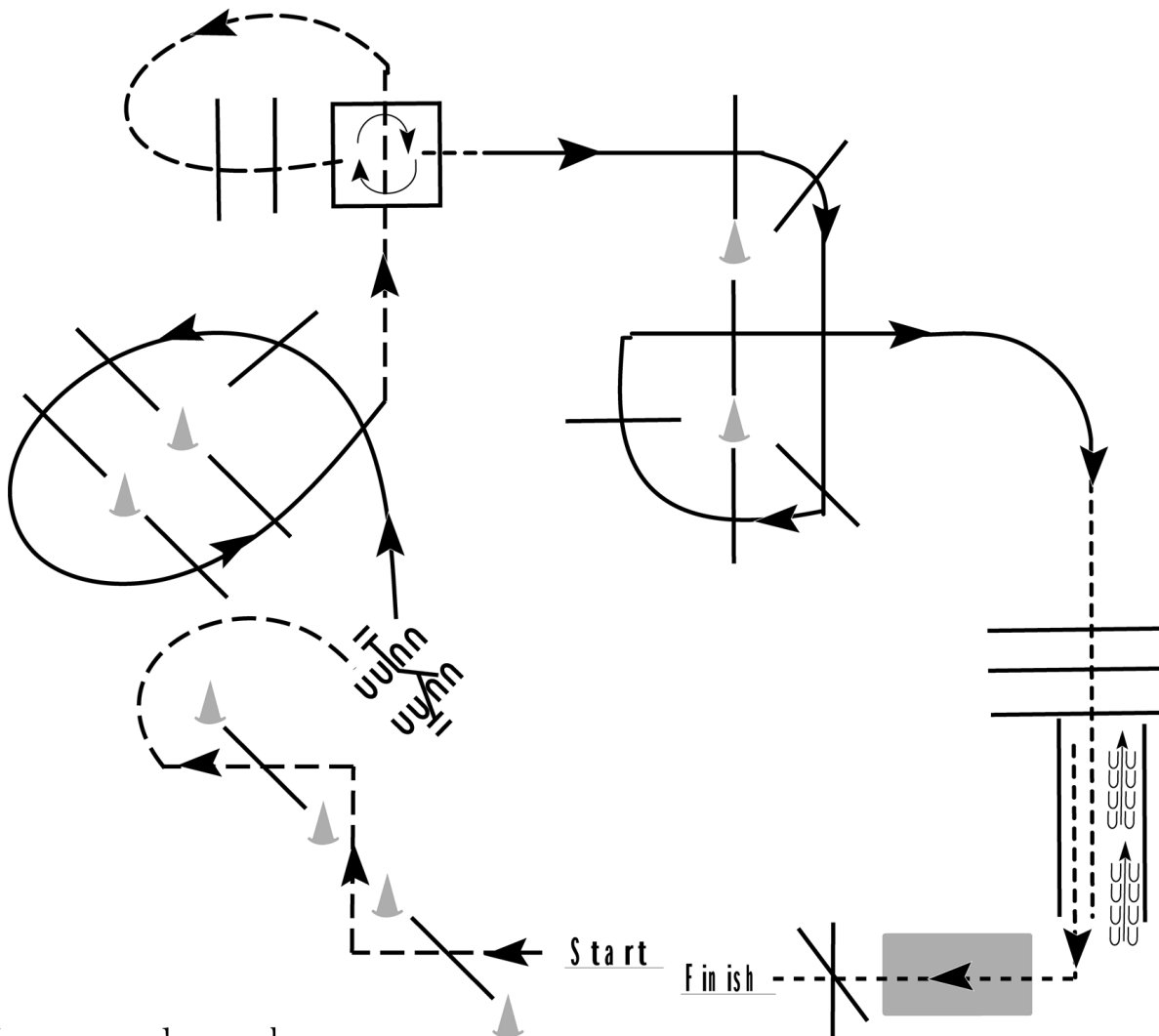

1. Jog over poles as shown.
2. Work gate with left hand.
3. Lope on left lead over poles.
4. Jog thru box, over poles and into box.
5. Turn 360 degrees to the right and walk out.
6. Lope on right lead over poles.
7. Walk over poles and into chute; back the chute.
8. Walk out of chute, over bridge and over final elevated pole to finish.

<b>Walk</b>	-----
<b>Jog</b>	- - - - -
<b>Extended Jog</b>	-----
<b>Lope</b>	=====
<b>Leg Yield</b>	
<b>Lead Change</b>	↘ ↙
<b>Back</b>	← ← ←
<b>Marker</b>	Ⓚ
<b>Sidepass</b>	← ← ←

[T/3-37]

**Pattern Provided by:**  
*Shannon Walker*

# 2026 Nationals Yr/2YO/3YO Led Trail

www.HorseShowPatterns.com

www.HorseShowPatterns.com

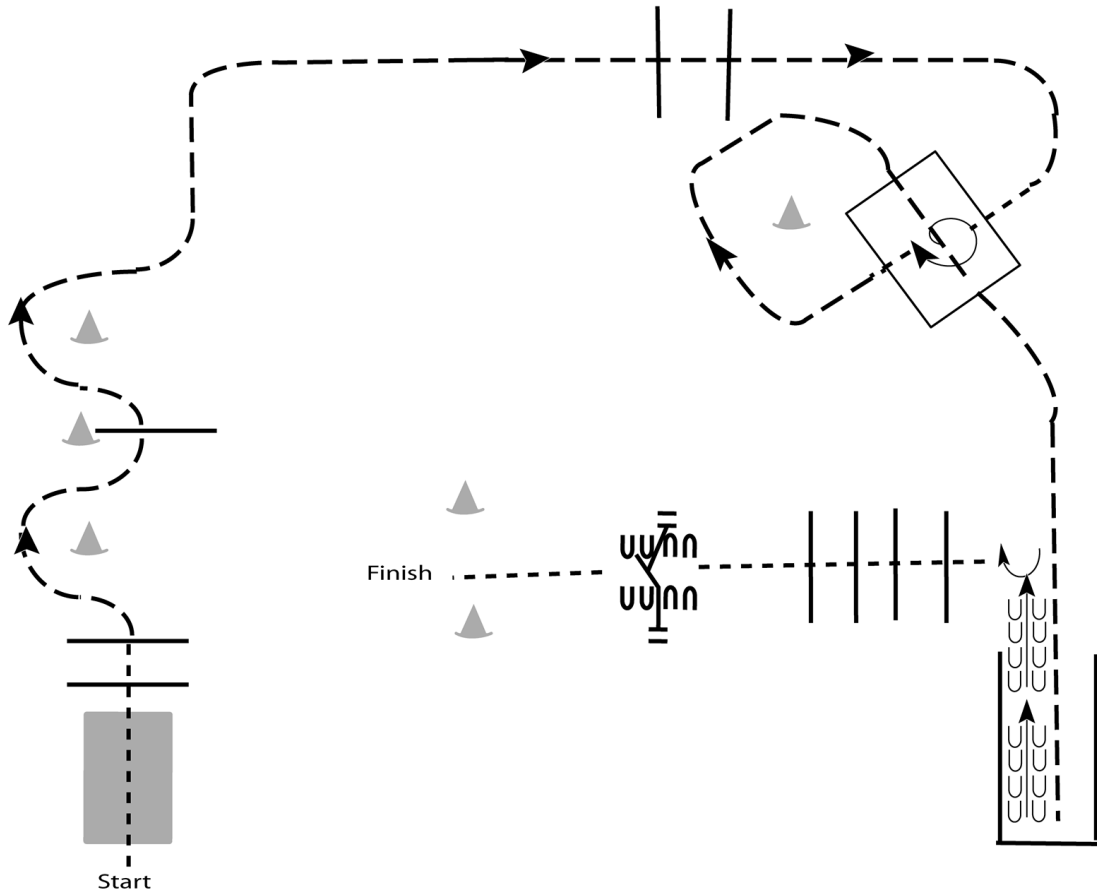

1. Walk over bridge and over poles.
2. Jog through serpentine and over pole.
3. Continue to jog over poles.
4. Break to a walk and walk into box. Turn a full turn to the right and walk out of box.
5. Jog through box and into chute
6. Back out of chute
7. Turn 90 degrees and walk over poles to gate
8. Work gate and walk to finish

<b>Walk</b>	-----
<b>Jog</b>	-----
<b>Extended Jog</b>	-----
<b>Lope</b>	—————
<b>Leg Yield</b>	
<b>Lead Change</b>	—/—
<b>Back</b>	←←←←←
<b>Marker</b>	Ⓚ
<b>Sidepass</b>	←-----→

**Pattern Provided by:**

*Shannon Walker*

# 2026 Nationals EWD / Small Fry/ Walk Trot Trail

www.HorseShowPatterns.com

www.HorseShowPatterns.com

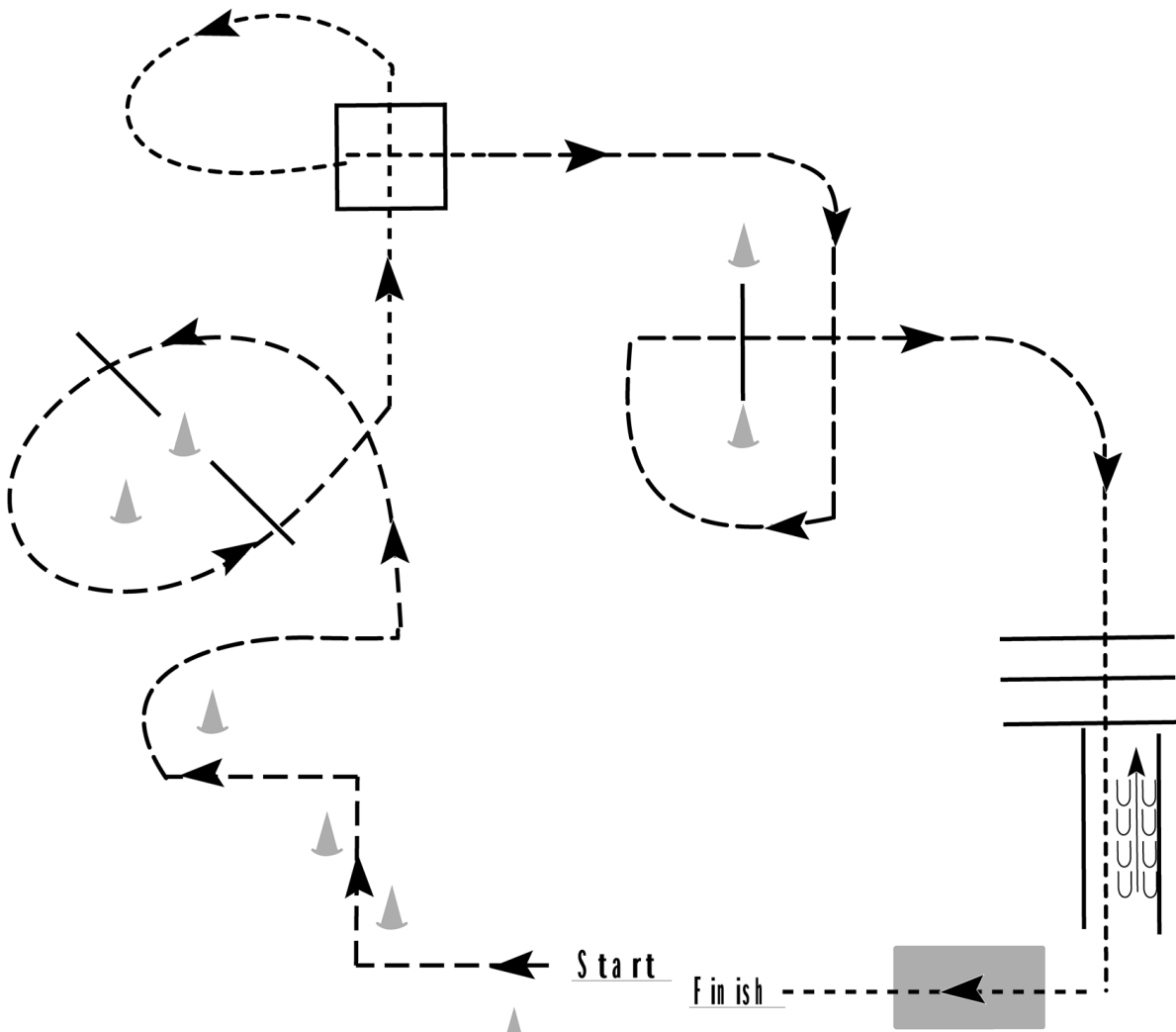

1. Jog thru serpentine as shown.
2. Jog over 2 poles.
3. Walk thru box twice as shown.
4. Jog over pole as shown.
5. Walk over poles and into chute.
6. Back up in the chute.
7. Walk out of chute and over bridge to finish.

Walk	-----
Jog	- - - - -
Extended Jog	— — — — —
Lope	—————
Leg Yield	
Lead Change	— / —
Back	← ← ← ← ←
Marker	Ⓚ
Sidepass	← — — — — →

[T/WT-37]

**Pattern Provided by:**  
*Shannon Walker*

# 2026 Nationals Jr. Youth/ Novice Amateur/Jr. Horse Trail

www.HorseShowPatterns.com

www.HorseShowPatterns.com

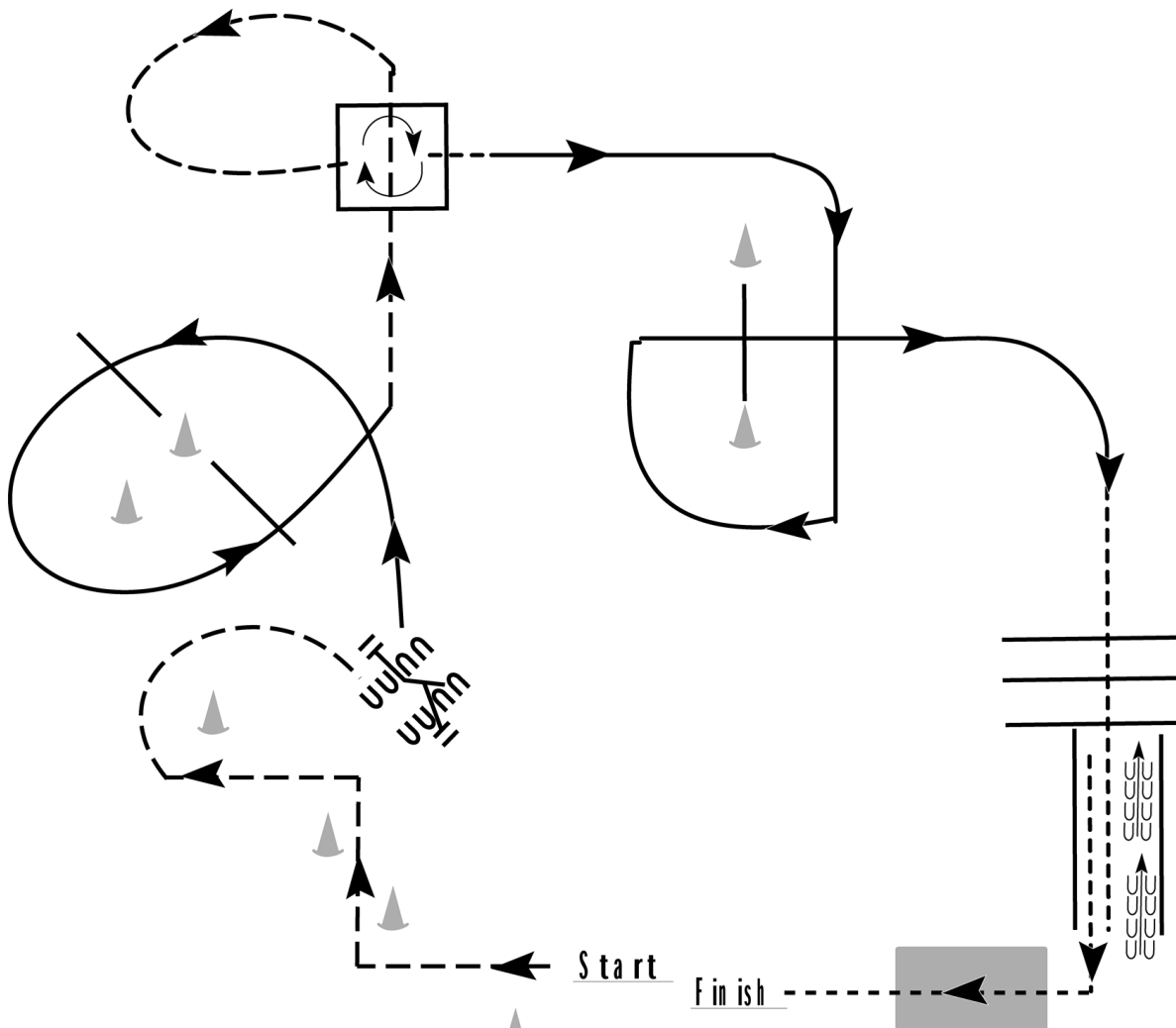

1. Jog thru serpentine as shown.
2. Work gate with left hand.
3. Lope on left lead over 2 poles.
4. Jog thru box and into box.
5. Turn 360 degrees to the right and walk out.
6. Lope on right lead over pole as shown.
7. Walk over poles and into chute; back the chute.
8. Walk out of chute, over bridge to finish.

<b>Walk</b>	-----
<b>Jog</b>	- - - - -
<b>Extended Jog</b>	-----
<b>Lope</b>	=====
<b>Leg Yield</b>	
<b>Lead Change</b>	///
<b>Back</b>	←←←
<b>Marker</b>	Ⓚ
<b>Sidepass</b>	←←←

[T/1-37]

**Pattern Provided by:**

*Shannon Walker*

# 2026 Nationals

## Sr. Youth/ Amateur/Masters Amateur/3YO/Sr. Horse Trail

www.HorseShowPatterns.com

www.HorseShowPatterns.com

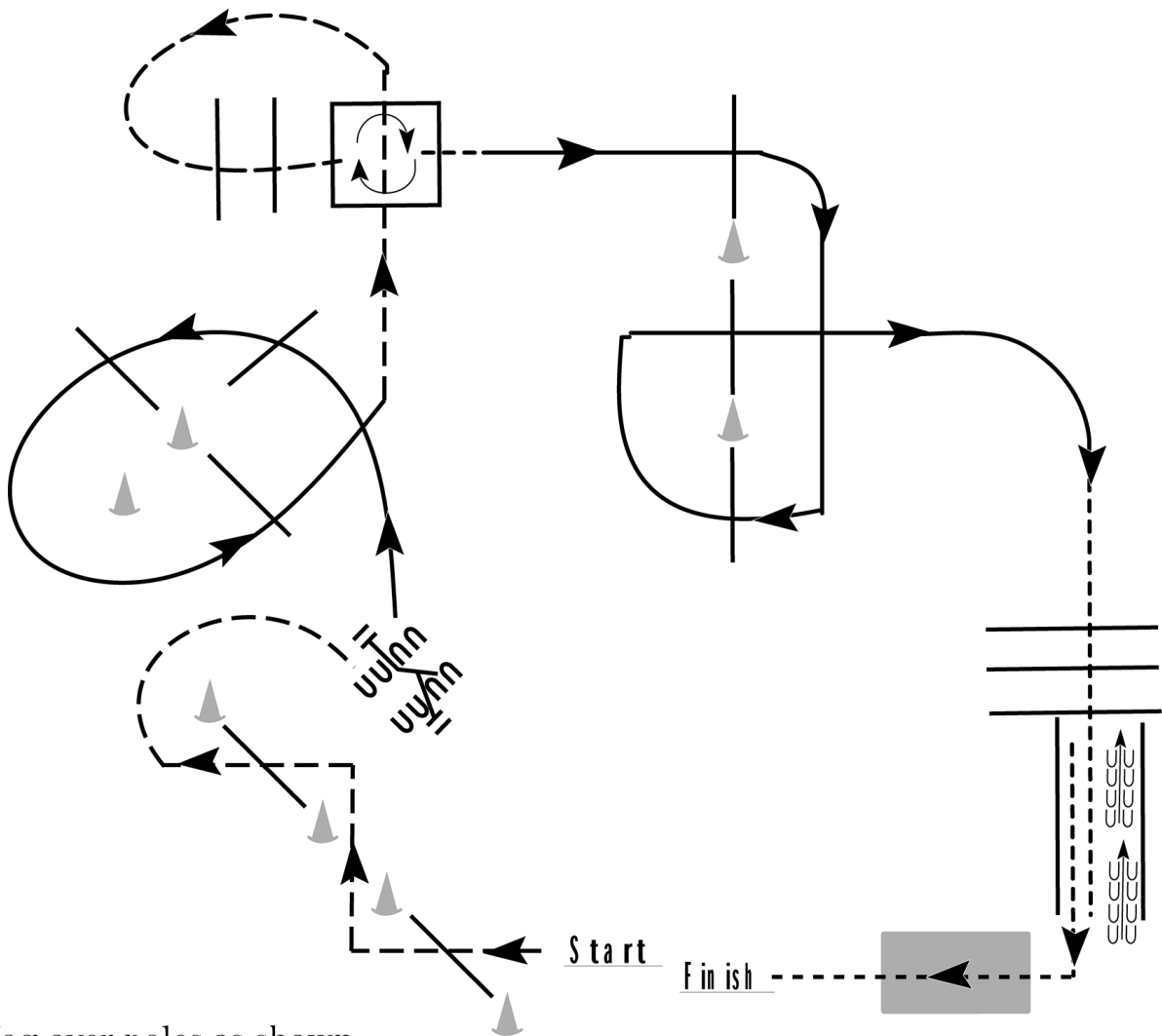

1. Jog over poles as shown.
2. Work gate with left hand.
3. Lope on left lead over poles.
4. Jog thru box, over poles and into box.
5. Turn 360 degrees to the right and walk out.
6. Lope on right lead over poles.
7. Walk over poles and into chute; back the chute.
8. Walk out of chute and over bridge to finish.

<b>Walk</b>	-----
<b>Jog</b>	- . - . - .
<b>Extended Jog</b>	-----
<b>Lope</b>	-----
<b>Leg Yield</b>	
<b>Lead Change</b>	///
<b>Back</b>	←←←
<b>Marker</b>	ⓑ
<b>Sidepass</b>	←-----←

[T/2-37]

**Pattern Provided by:**

*Shannon Walker*

# RANCH TRAIL

## All Led Prospects

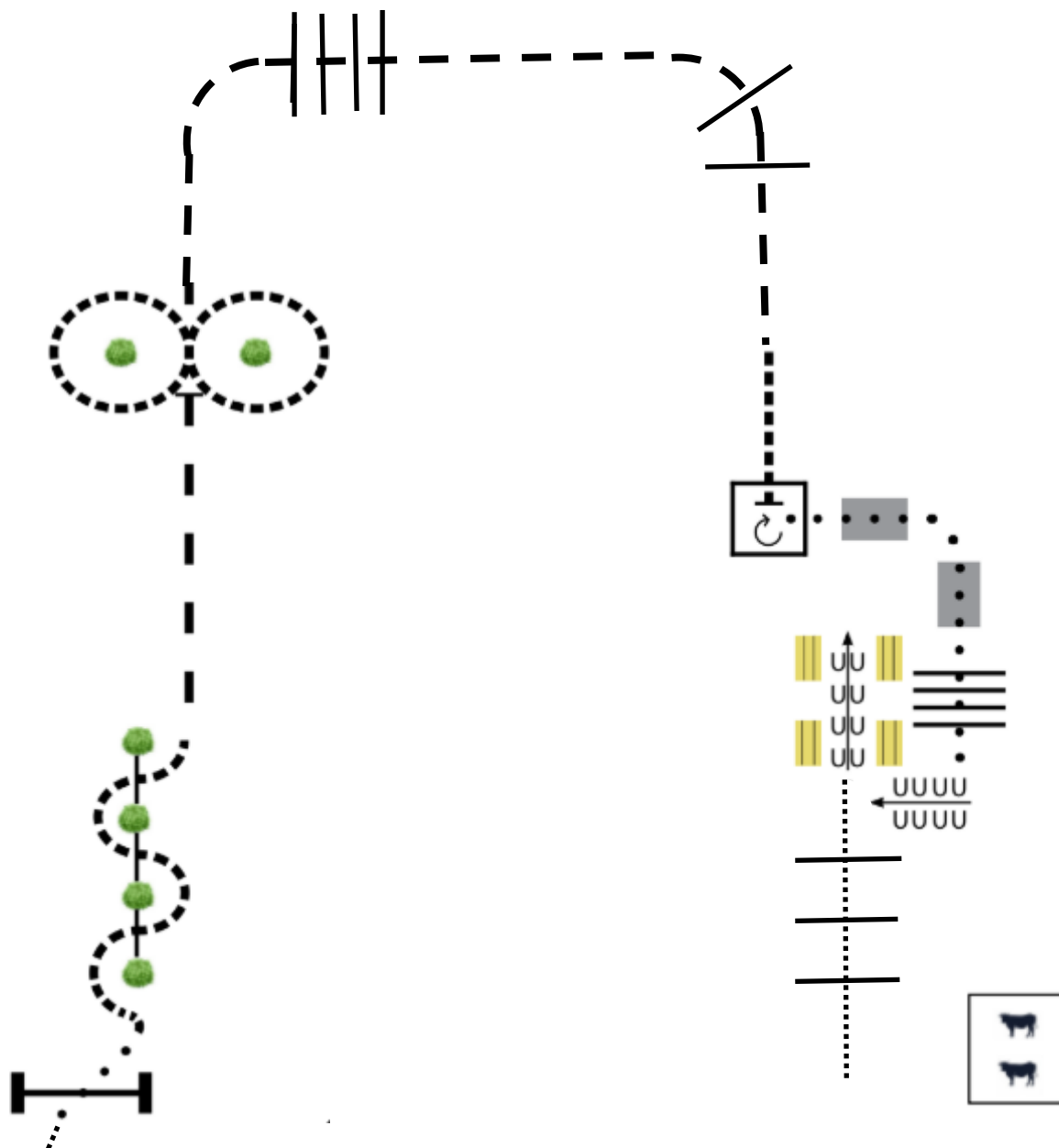

1. Work gate left hand
2. Trot serpentine, extend trot to rope
3. Pick up rope and walk figure 8 to left first. Replace rope on pole
4. Trot to and over poles, into box
5. Turn 270 right, walk out and over bridges
6. Walk over poles, then sidepass right
7. Back chute of hay bales
8. Walk out & over poles
9. Stop and feed cattle, lead out to finish

